

< 四方内反 >

081024

刃



台
豆平鉈の面を切る前まで
7<ok>おく

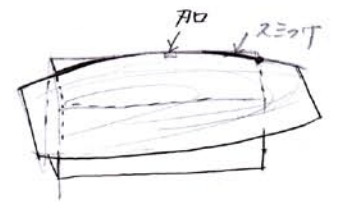
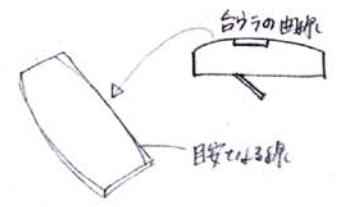
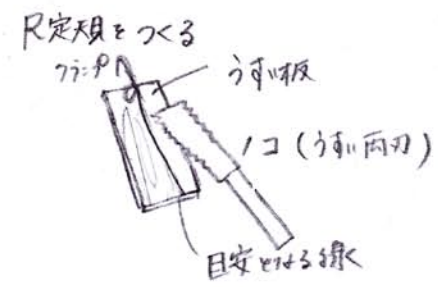
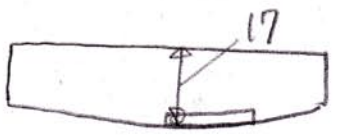
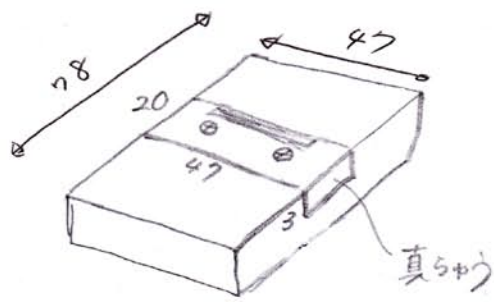
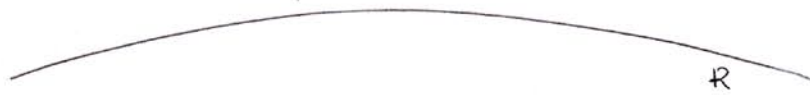

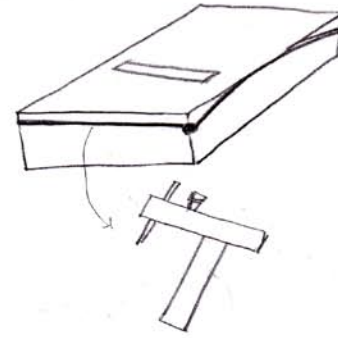
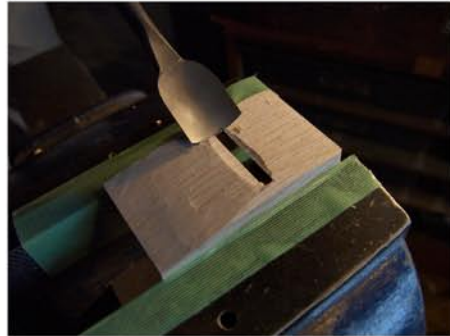

スミを押し返す反対にRをつける。

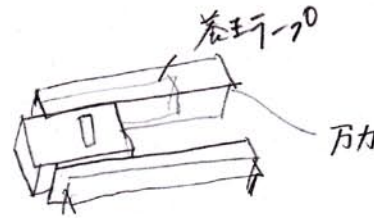
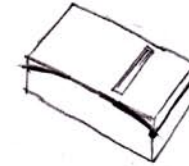

力にはさま。



豆=方反飽せ
内反りきついに取る

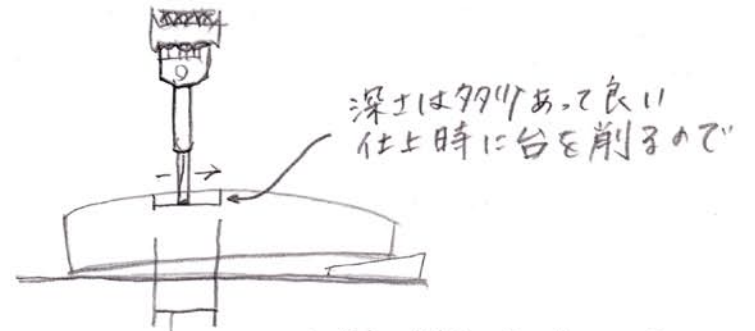
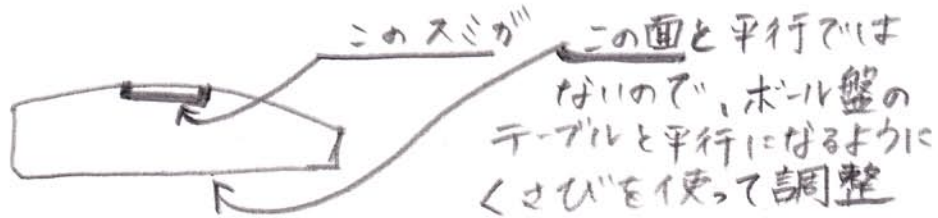

・台に真鍮板を入れる為の
ミゾをほる

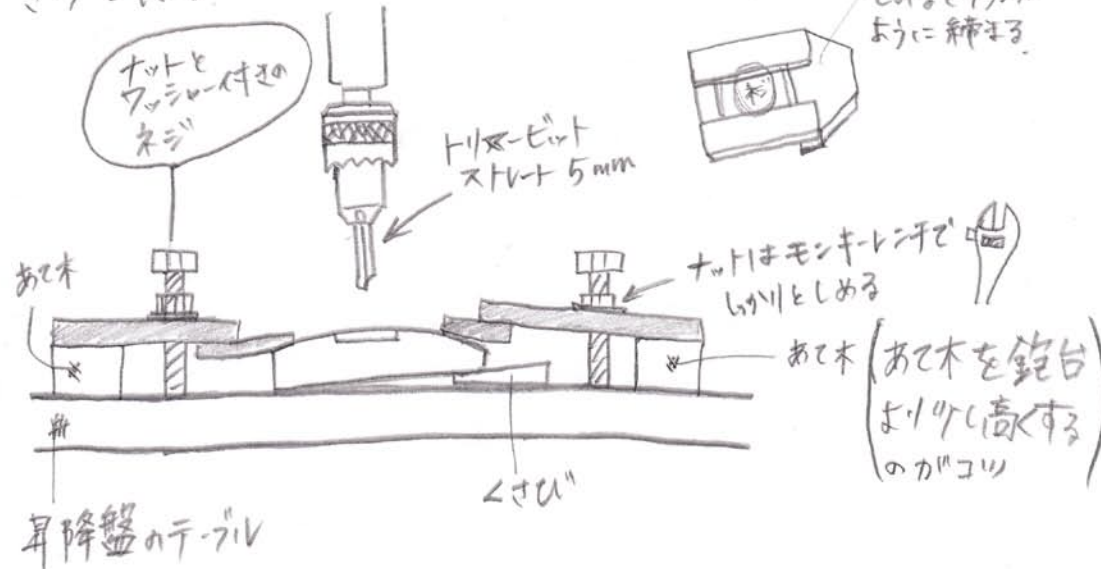

・スミの内側を削る。ピタリにした方がいいので、この時は刃に狭いくらいがいい。後に削る。
※エッジなると真鍮からやり直しになる。