

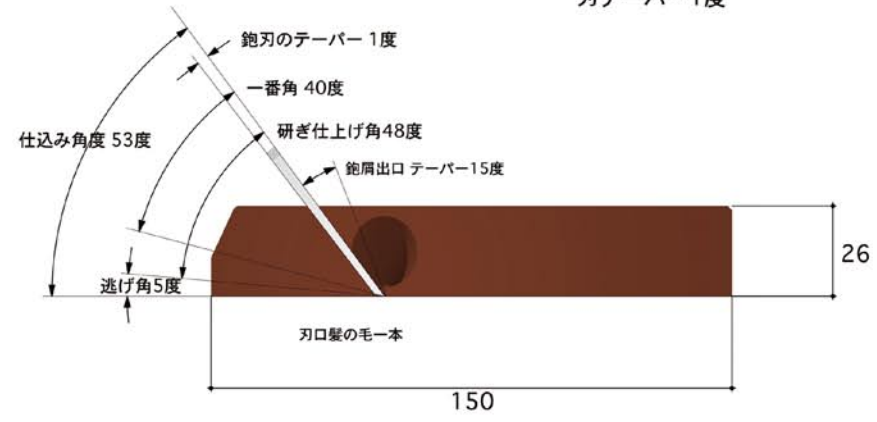

際鉋立て刃24mm右

鉋台 赤檜
 刃材質HSS
 刃先端部厚み2.8mm
 刃テーパ1度



・ 際鉋

081030

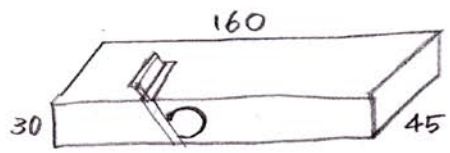

刃先線のスミをつける

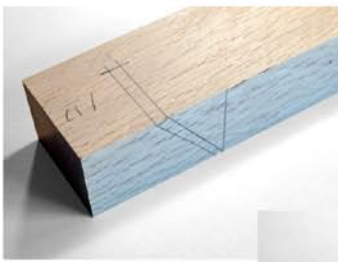
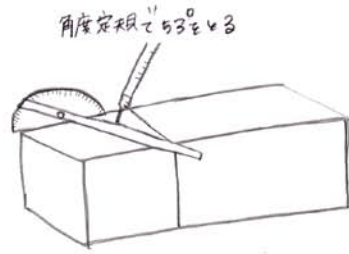
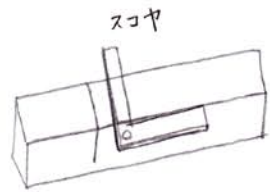

刃を合せてあかす

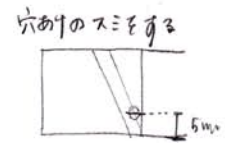
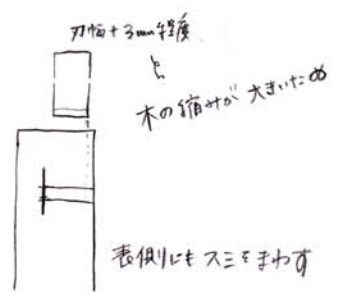

木工用
ドリルビット 4.0φ

木工用
ドリルビットの
穴をあける

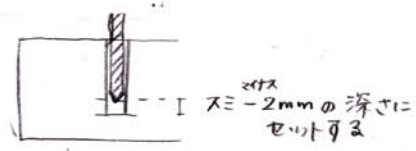

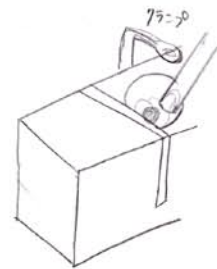
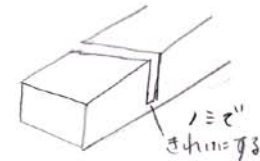
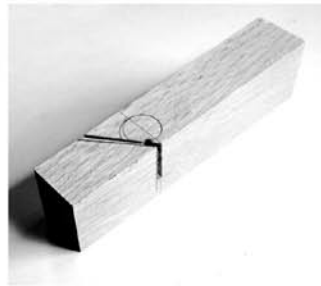
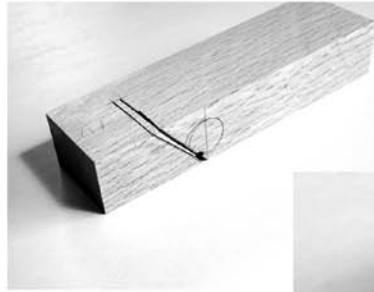
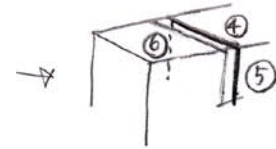
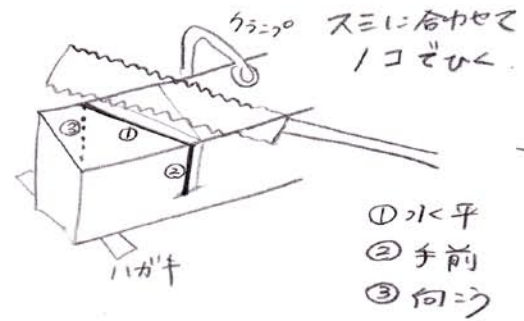
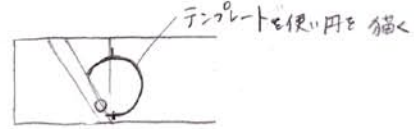
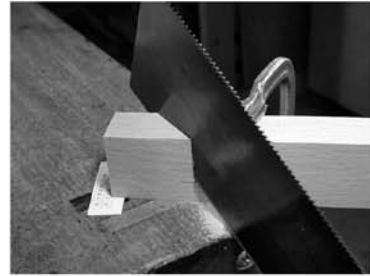
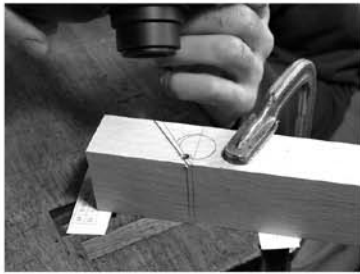

ノミで 放射状に削る → 臺の中心と奥を合わせる

常にドリルの穴に 向かって削る。

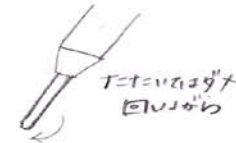



・際鉋

081030

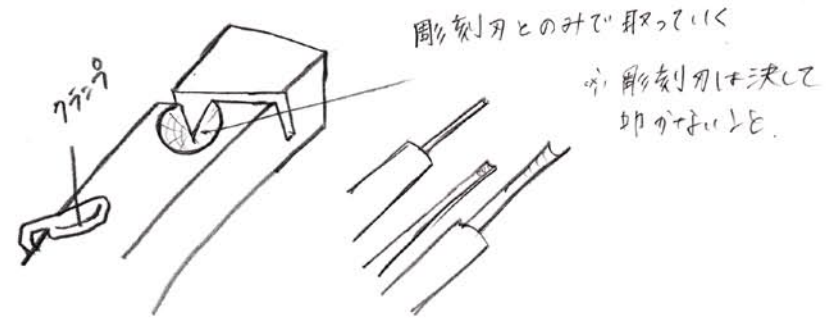

彫刻刀とのみで取っていく

彫刻刀は決して
叩かないと。

● ほしいところを取れたら、小刀を使って
なめらかにしていく。



さの目があるので
小刀は2種類
使う。



● 1度、刃を入れて、どしどしが当たるか
石直さ思えばかり、スクレイパーで
調整していく。

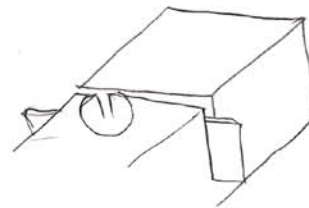

3

